

# PHILIPP GROUP

## PHILIPP Lifting insert with cross hole



VB3-T-011-en - 01/18

**Installation and Application Instruction**

**PHILIPP Lifting insert with cross hole**

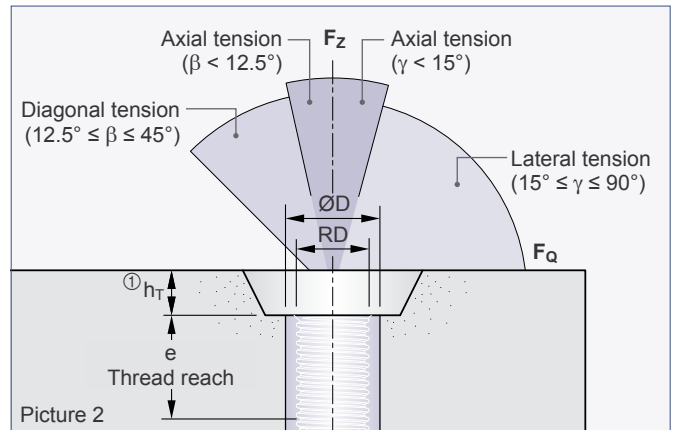
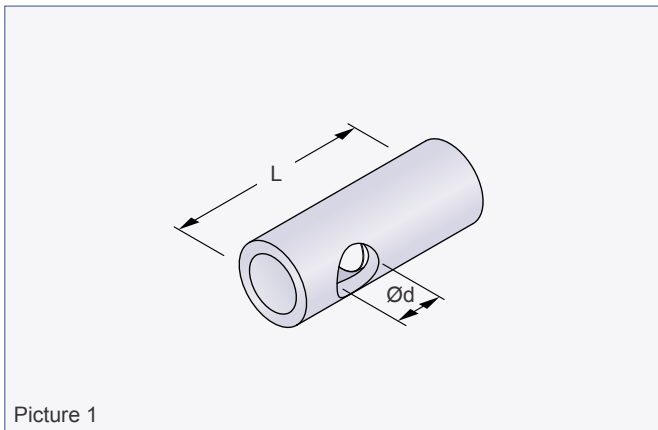

The Lifting insert with cross hole is part of the PHILIPP Transport anchor system and complies with the VDI/BV-BS Guideline "Lifting inserts and lifting insert systems for precast concrete elements" (VDI/BV-BS 6205). The use of Lifting inserts with cross hole requires the compliance with this Installation Instruction as well as the General Installation Instruction. The Installation and Application Instructions for the belonging PHILIPP lifting devices (Lifting loop with threaded end, Adapter for lateral tension, "Wirbelstar", "Lifty") as well as the data sheets of the belonging PHILIPP

accessories (Plastic nailing plates, Retaining caps KH etc.) must be followed also. The anchor may only be used in combination with the mentioned PHILIPP lifting devices. Lifting inserts with cross hole are designed for the transport of precast concrete units only. Multiple use within the transport chain (from production to installation of the unit) means no repeated usage. This Installation and Application Instruction does not specify a repeated usage (e.g. ballasts for cranes) or a permanent fixation.

**Table 1: Dimensions**

Ref.-No. bright zinc plated	Ref.-No. stainless steel	Type	Dimensions					Weight [kg/100 pcs.]
			RD	ØD [mm]	L [mm]	e [mm]	Ød [mm]	
71HM12	77HM12VA	RD 12	12	15.0	40	22	8	2.0
71HM14	77HM14VA	Type RD 14 of the threaded transport anchor system is no longer available					10	4.0
71HM16	77HM16VA	RD 16	16	21.0	55	27	13	6.0
71HM18	77HM18VA	Type RD 18 of the threaded transport anchor system is no longer available					13	11.0
71HM20	77HM20VA	RD 20	20	27.0	67	35	16	13.0
71HM24	77HM24VA	RD 24	24	31.0	77	43	18	18.0
71HM30	77HM30VA	RD 30	30	39.5	105	56	23	44.0
71HM36	77HM36VA	RD 36	36	47.0	125	68	27	72.0
71HM42	77HM42VA	RD 42	42	54.0	145	75	32	110.0
71HM52	77HM52VA	RD 52	52	67.0	195	95	40	220.0

① Mind the embedment depth  $h_T$  of the corresponding nailing plate and retaining cap (Picture 2).

**Material**

Lifting inserts with cross hole are made of a special high precision steel. An internal sealing cap closes the threaded part of the insert in order to avoid the infiltration of concrete. A U-shaped stirrup acc. to table 3 is led through the cross hole to transfer the loads into the element (s. Picture 6). The Lifting inserts with cross hole are galvanised acc. to common standards. This galvanisation protects the anchor temporarily from the storage at the producer site to the final installation in the concrete element.

If the surface of a concrete element has to fulfil special conditions (e.g. no stream of rust) the Lifting insert with cross hole can be delivered in stainless steel SS 316 alternatively.



The EC Declaration of Conformity (DoC) of the Lifting insert with cross hole is available on request or can be downloaded from our website [www.philipp-group.de](http://www.philipp-group.de).



## Bearing capacities

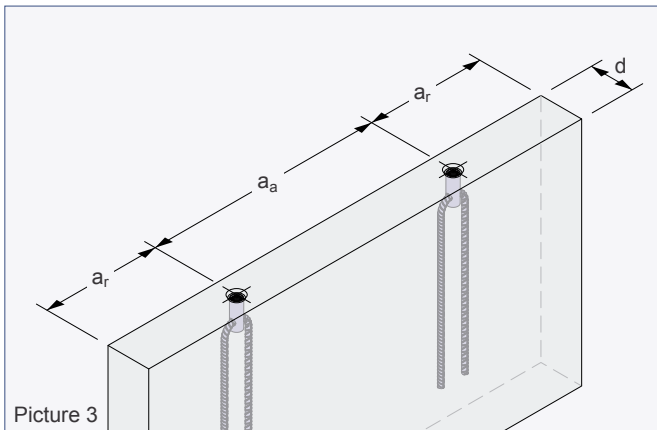

Picture 3

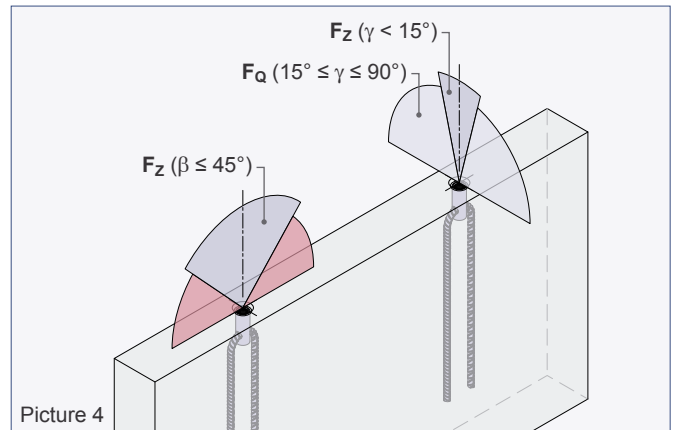

Picture 4

### Element thicknesses, centre and edge distances

The installation and position of Lifting inserts with cross hole in precast concrete units require minimum element dimensions and distances for a safe load transfer.

Table 2 shows the minimum thickness  $d$  of a unit to cover all load directions (axial, diagonal and lateral).

**Table 2: Permissible load bearing capacities**

Load class	Element thicknesses and distances			perm. F if $f_{cc} \geq 15 \text{ N/mm}^2$	
	$d$ [mm]	$a_a$ [mm]	$a_r$ [mm]	Axial tension / diagonal tension perm. $F_z$ $0^\circ - 45^\circ$ [kN]	Lateral tension perm. $F_Q$ [kN]
12	60 ②	300	150	5.0	2.5
14	70 ②	400	200	8.0	4.0
16	85	400	200	12.0	6.0
18	95	500	250	16.0	8.0
20	105	550	275	20.0	10.0
24	120	600	300	25.0	12.5
30	140	650	350	40.0	20.0
36	200	800	400	63.0	31.5
42	240	1000	500	80.0	40.0
52	275	1200	600	125.0	62.5

② With lateral tension a minimum unit thickness of 80 mm is required.

- To determine the correct type please refer also to our General Installation and Application Instruction.

- The weight of 1.0 t corresponds to 10.0 kN.

Under lateral tension the Lifting inserts have only half of the capacity compared to axial loading. However, this is not a

limitation because during tilt-up only half of the weight has to be lifted (please refer to the General Installation Instruction).

## Reinforcement

### Main reinforcement / axial tension

With use of Lifting inserts with cross hole precast units must be reinforced with a minimum reinforcement (Table 3). This minimum reinforcement can be replaced by a comparable steel bar reinforcement. At the first time of lifting the concrete must have a minimum strength  $f_{cc}$  of **15 N/mm<sup>2</sup>**. The user is personally responsible for further transmission of load into the concrete unit.



Existing static or constructive reinforcement can be taken into account for the minimum reinforcement according to Table 3.

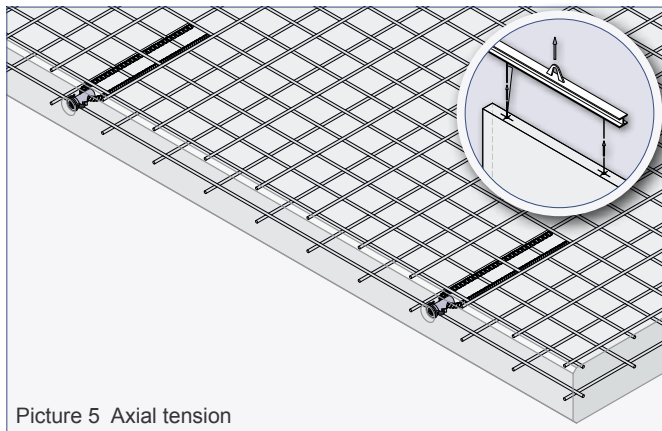

Picture 5 Axial tension

**Table 3: Minimum reinforcement**

Load class	Mesh reinforcement (square) [mm <sup>2</sup> /m]	Reverse reinforcement (B500B)			
		Ød <sub>SB</sub> [mm]	Ød <sub>brB</sub> [mm]	L <sub>B</sub> [mm]	Cut length [mm]
12	188 (single mesh)	6	24	240	490
14	188 (single mesh)	8	32	280	570
16	188 (single mesh)	10	40	330	670
18	188	10	40	420	850
20	188	12	48	440	890
24	188	14	56	480	970
30	188	16	64	650	1320
36	188	20	140	820	1670
42	188	25	175	900	1830
52	188	28	196	1300	2640

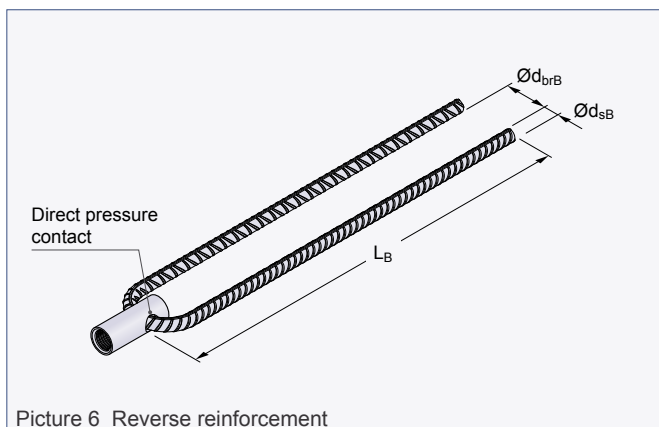

Picture 6 Reverse reinforcement

### Additional reinforcement for diagonal tension

If the Lifting insert with cross hole is used under diagonal tension  $\beta > 12.5^\circ$  an additional reinforcement according to Table 4 is required. Here the reinforcement for diagonal tension is placed contrarily to the tensile direction (Picture 7) and must have direct pressure contact to the anchor insert in the peak of its bending.

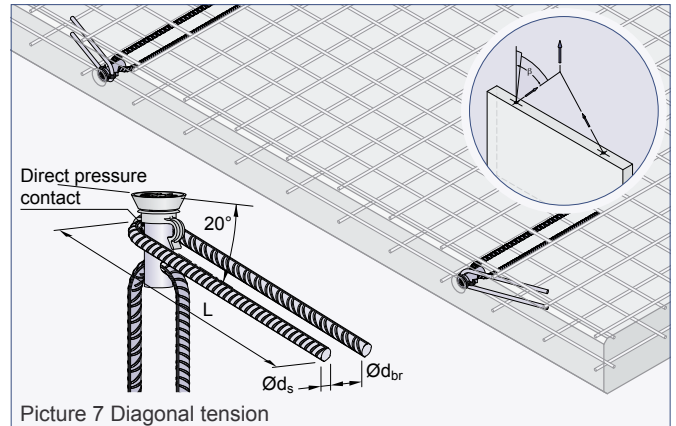

Picture 7 Diagonal tension



Position of the direct pressure contact between Lifting insert and additional reinforcement must be within the thread reach of the Lifting insert. This is guaranteed by using the Marking ring with clip (74KR\_\_CLIP or 74\_\_CLIPVA).

Table 4 shows possibilities to use appropriate steel diameters if the inclination is less than  $30^\circ$ . Decisive for the choice of the stirrups are the existing diagonal inclinations during the transport chain until the final mounting of the precast element.

**Table 4: Additional reinforcement for diagonal tension (material B500B) (required if  $\beta > 12.5^\circ$ )**

Load class	if $12.5^\circ \leq \beta \leq 45^\circ$			if $12.5^\circ \leq \beta \leq 30^\circ$		
	Ød <sub>s</sub> [mm]	L [mm]	Ød <sub>br</sub> [mm]	Ød <sub>s</sub> [mm]	L [mm]	Ød <sub>br</sub> [mm]
12	6	150	24	6	150	24
14	6	200	24	6	200	24
16	8	200	32	6	200	24
18	8	250	32	8	200	32
20	8	300	32	8	250	32
24	10	300	40	8	300	32
30	12	400	48	10	350	40
36	14	550	56	12	450	48
42	16	600	64	14	550	56
52	20	750	140	16	700	67

## Reinforcement

### Additional reinforcement for lateral tension

If an anchor is loaded by lateral tension where the inclination is  $\gamma \geq 15^\circ$  an additional reinforcement is required (Table 5). This reinforcement for lateral tension is installed in the front side of the element contrarily to the tensile direction (Picture 8) and must have direct pressure contact to the Lifting insert with cross hole in the peak of its bending. Lateral forces on Lifting inserts with cross hole are only possible with wall thicknesses  $d$  acc. to Table 2. Tilting of walls can cause diagonal and lateral tension at the same time (Picture 8). The reinforcement for lateral tension covers this load direction as well as diagonal tension. During mounting the turn-over or tilt-up of the unit requires attention regarding the position of the reinforcement. With lateral tension the mesh reinforcement (Table 2) must be applied as a mesh cap. In addition to the mesh cap longitudinal reinforcement must be installed as shown in Table 5.

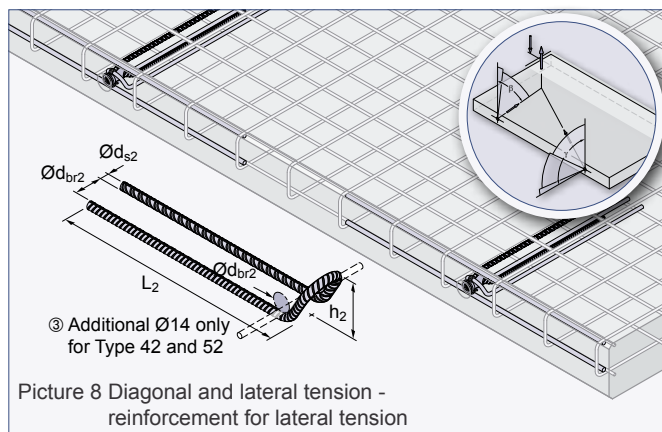

Picture 8 Diagonal and lateral tension - reinforcement for lateral tension

### Note for reinforcement in thin elements

In thin elements (single mesh) it might be necessary to cut the longitudinal reinforcement close to the insert (counter brace) in order to have enough concrete cover in this area.

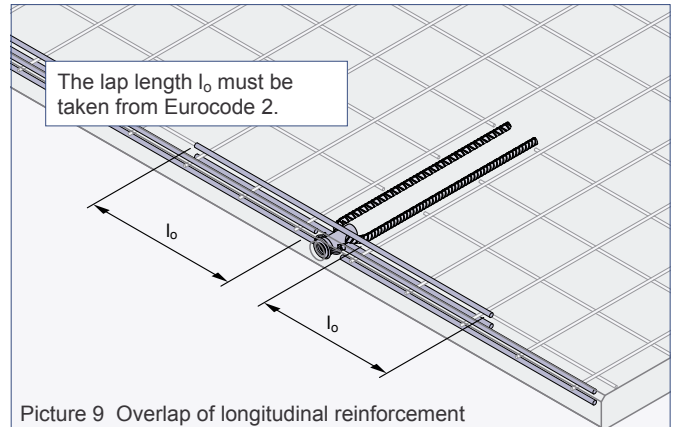

Picture 9 Overlap of longitudinal reinforcement

**Table 5: Reinforcement for lateral tension**  
(material B500B) (required if  $\gamma \geq 15^\circ$ )

Load class	$\text{Ø}d_{s2}$ [mm]	$L_2$ [mm]	$h_2$ [mm]	$\text{Ø}d_{br2}$ [mm]	Longitudinal reinforcement $\text{Ø} \times \text{length}$ [mm]
12 ②	6	270	33	24	$\text{Ø}10 \times 850$
14 ②	6	350	35	24	$\text{Ø}10 \times 850$
16	8	420	38	32	$\text{Ø}10 \times 850$
18	8	460	47	32	$\text{Ø}12 \times 850$
20	10	490	56	40	$\text{Ø}12 \times 850$
24	12	520	67	48	$\text{Ø}12 \times 850$
30	12	570	81	48	$\text{Ø}16 \times 1000$
36	14	690	117	56	$\text{Ø}16 \times 1000$
42 ③	16	830	143	64	$\text{Ø}16 \times 1000$
52 ③	20	930	163	140	$\text{Ø}20 \times 1200$

② Minimum element thickness of 80mm is required.

③ Additional  $\text{Ø}14$ , length = 60 cm (see Picture 8)

Notes

A large grid of graph paper for taking notes, consisting of 20 columns and 30 rows of small squares.